



- Designed for feeding of high-speed presses
- Movement transmission to the mobile unit through wheel gear
- Sheet holding through fixed gripper during feeding gripper opening and mobile unit return stroke
- Fixed gripper lifting system through cam
- Pitch adjustment through graduated vernier

## RANGE AND FEATURES

Model	Width		Feed length (mm)	Thickness (mm)		Weight (kg)
	Min.	Max.		Min.	Max.	
	(mm)			(mm)		
<b>1621 X</b>	10	132	5 - 130	0.1	2.5	75
<b>1621 A</b>	14	203	5 - 200	0.1	2.5	120
<b>1621 B</b>	30	305	10 - 300	0.2	3.0	235
<b>1621 C</b>	30	407	10 - 400	0.2	3.0	300

## DIMENSIONS

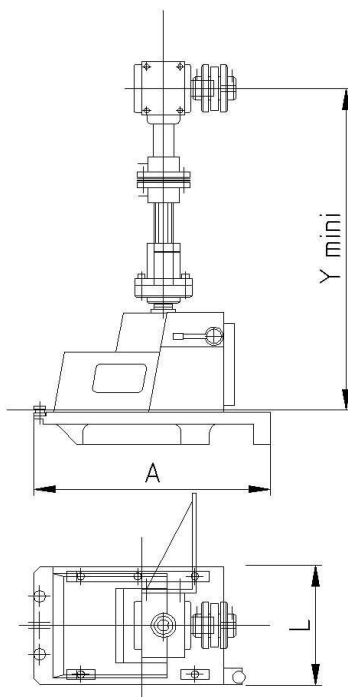

Model	L	A	B
<b>1621 X</b>	295	510	635
<b>1621 A</b>	380	670	645
<b>1621 B</b>	510	880	860
<b>1621 C</b>	610	1080	860